



## P1808 Flow and Sizing Coefficients

Type	Flow Coefficients (Wide-Open)		C <sub>1</sub>	K <sub>m</sub>	IEC Sizing Coefficients		
	C <sub>g</sub>	C <sub>v</sub>			X <sub>r</sub>	F <sub>L</sub>	F <sub>D</sub>
1808	1410	40.1	35.2	0.79	0.78	0.89	0.50
1808 with Angle Body	1800	51.4	35	0.76	0.78	0.87	0.50

## P1808 Inlet Pressure

Maximum Inlet Pressure	150 PSIG
------------------------	----------

## P1808 Capacities<sup>1</sup> Using Internal Control Line and a Pilot with High-Gain Restriction

Relief Pressure Setting		Capacity in Thousands of SCFH (Nm <sup>3</sup> /h) of 0.6 Specific Gravity Natural Gas							
		Pressure Build-up in PSIG Over Relief Pressure Setting							
PSIG	BAR	2	6	10	15	20	25	30	
5	0.34	32	46	50	61	70	80	89	
12	0.83	41	55	65	74	84	93	102	
20	1.4	56	73	80	89	99	108	117	
30	2.1	67	89	99	108	117	127	136	
40	2.8	85	105	120	127	136	145	154	
50	3.5	94	120	137	145	154	163	172	
60	4.1	..	135	152	163	172	181	190	
70	4.8	..	150	168	161	190	200	209	
80	5.5	..	161	180	200	201	218	227	
90	6.2	..	170	192	213	227	236	245	
100	6.9	..	183	209	231	245	254	263	
110	7.6	..	197	223	246	263	276	281	
125	8.6	..	201	241	267	284	298	..	

.. Shaded areas indicate capacities with main valve wide-open.

1. Capacities based on 0 PSIG (0 BAR) outlet pressure. If outlet pressure is not 0 PSIG (0 BAR), shaded capacities may be recalculated using the wide-open C<sub>g</sub> and the desired pressure drop.

## P1808 Capacities Using Optional External Control Line and a Pilot with High-Gain Restriction

Set Pressure Range, PSIG (BAR)	Set Pressure <sup>1</sup>		Buildup Over Set Pressure to Begin Opening Main Valve <sup>2</sup>		Buildup Over Set Pressure to Fully Open Main Valve <sup>3</sup>		Pressure Drop Below Set Pressure to Reset Pilot		Capacities of 0.6 Specific Gravity Natural Gas <sup>4</sup>	
	PSIG	BAR	PSIG	BAR	PSIG	BAR	PSIG	BAR	SCFH	Nm <sup>3</sup> /h
3 to 18 (0.21 to 1.2)	3	0.21	0.9	0.06	6.0	0.41	1.0	0.07	37,000	992
	5	0.35	0.7	0.05	4.0	0.28			37,000	992
	10	0.69	0.7	0.05	1.2	0.08			42,000	1126
	15	1.0	0.7	0.05	1.0	0.07			52,000	1394
15 to 40 (1.0 to 2.8)	15	1.0	0.8	0.05	1.1	0.07	1.0	0.07	53,000	1420
	20	1.4							63,000	1688
	30	2.1							82,000	2198
	40	2.8							101,000	2707
35 to 125 (2.4 to 8.6)	40	2.8	1.4	0.09	1.9	0.13	1.0	0.07	102,000	2734
	50	3.5							121,000	3243
	60	4.1							139,000	3725
	70	4.8							157,000	4208
	80	5.5	1.6	0.11	2.2	0.15	1.0	0.07	176,000	4717
	90	6.2							194,000	5199
	100	6.9							213,000	5708
	110	7.6							231,000	6191
125	8.6	258,000	6914							

1. Set pressure is defined as the pressure at which the pilot exhaust starts to bubble (discharge).

2. Crack pressure is the inlet pressure at which the main valve starts audible flow.

3. Inlet pressure buildup over the set pressure to achieve wide-open capacity.

4. Capacities with inlet piping equal to body size and without outlet piping.

### P1808 Regulator Rebuild Kits

	Kit Includes	Part Number
P1808	Nitrile Diaphragm Assembly, Valve plug O-rings & backup O-rings, Casing/body gasket	971-180-800

### P1808 Dimensions

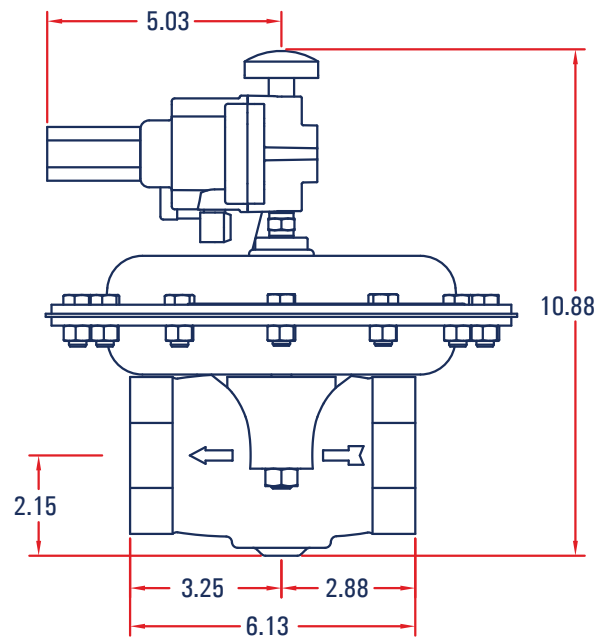
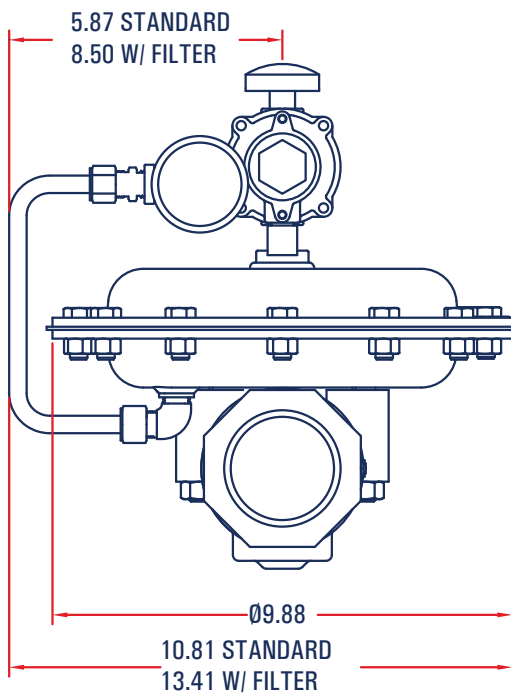

### Angle Body

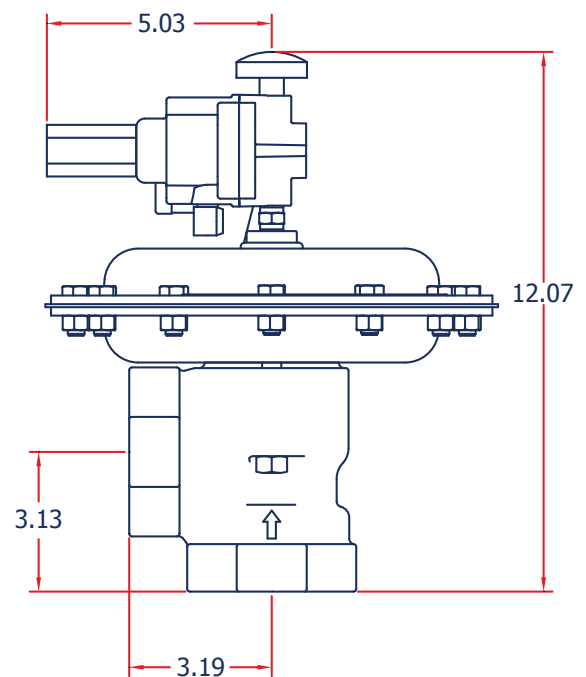
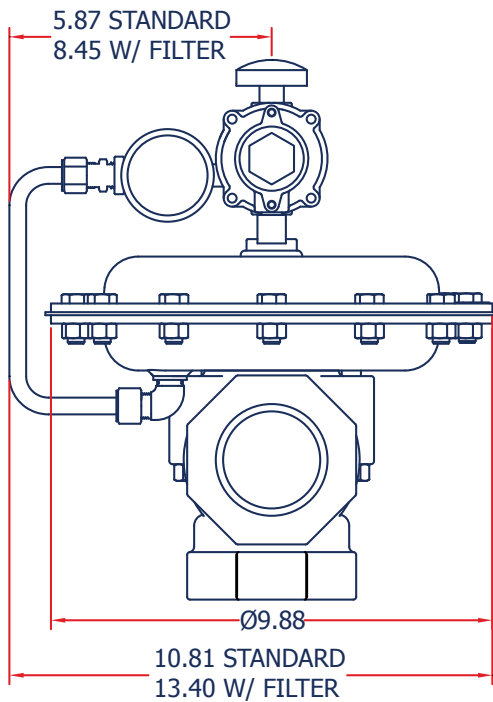

## P1808 Parts

Item	Description	Qty.	Part Number
1	Upper Casing, Steel	1	802-121-000
2	Lower Casing, Steel	1	802-122-000
3	Diaphragm Assembly	1	804-278-000
4	Upper Diaphragm Plate	1	638-080-000
5	Lower Diaphragm Plate	1	638-081-000
6	Valve Plug, Stainless Steel	1	639-121-000
7	O-ring Retainer	1	643-207-000
8	Body	1	2" NPT - Iron, Straight 664-387-000
	2" NPT - Steel, Straight 664-387-001		
	2" NPT - Iron, Angle 664-429-000		
9	Valve Plug Base O-ring - Nitrile	1	649-309-005
10	Valve Plug O-ring - Nitrile	1	649-309-006
19	Valve Plug Backup Ring	1	649-320-000
11	Upper Valve Plug O-ring - Nitrile	1	649-309-007
12	Spring	1	655-747-000
13	Valve Plug Bolt	1	648-467-006
14	Valve Plug Bolt Nut	2	634-201-000
15	Casing Build Screws	12	648-467-007
16	Casing Build Screws Nuts	12	634-151-000
17	Casing/Body Build Screws	2	603-010-000
18	Casing/Body Build Screw Nuts	2	634-202-000

Item	Description	Qty.	Part Number
20	Valve Plug Guide	1	626-113-000
21	Casing/Body Gasket	2	624-085-000
22	Name Plate	1	632-553-000
24	P590 Filter Assembly - Brass	1	P594
	P590 Filter Assembly - Stainless		P595
25	Hex Nipple - 1/4	1	622-056-000
26	Street T - 1/4 FxFxM	1	622-064-000
27	Compression Fttg. - 3/8 x 1/4 NPT	1	622-065-000
28	Elbow Compression Fttg. - 3/8 x 1/4 NPT	1	622-066-000
29	Vent	1	836-009-000
30	Pilot Tubing - Standard	1	660-083-000
	Pilot Tubing - With P590 Filter		660-083-001
31	0-160 PSI Gauge	1	GG20160C4
32	Consult PL82 / PL83 Pilot Regulator information data sheet in the BelGAS Product Binder in Tab entitled "Pilot's and Small Regs"	1	

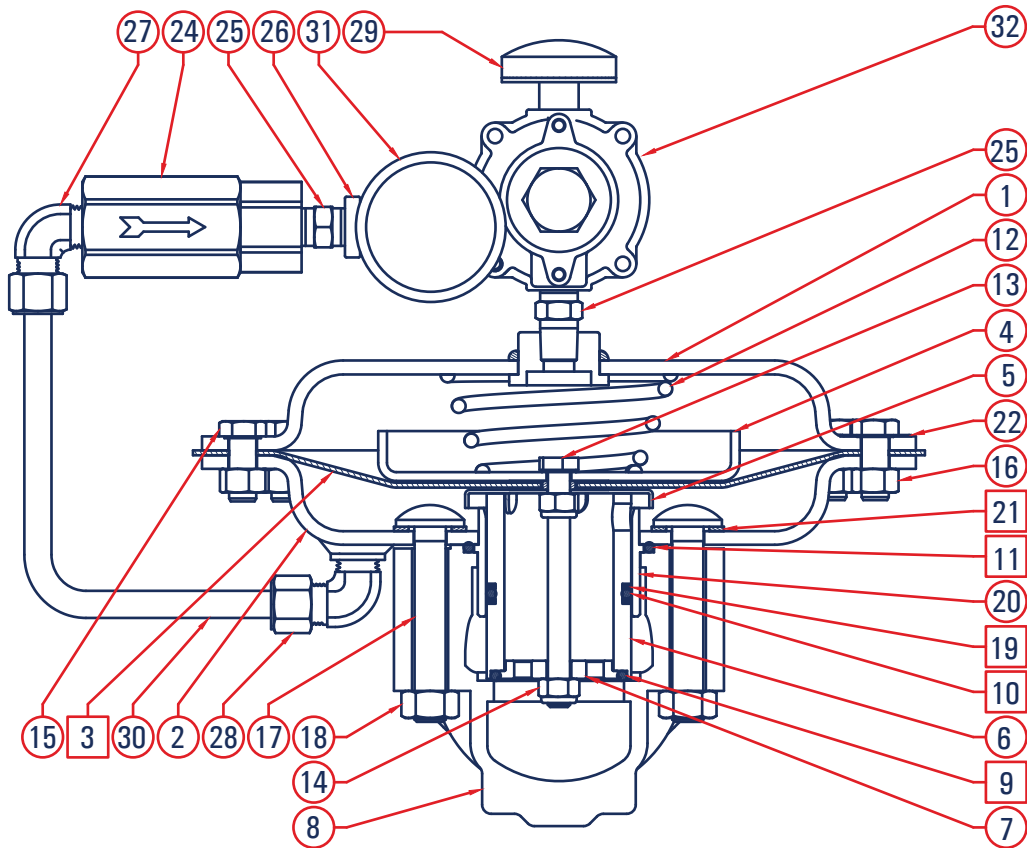

- PARTS INCLUDED IN REPAIR KITS 971-180-8XX